

Datasheet

AC Control Air Sinclair

Part No: 100587

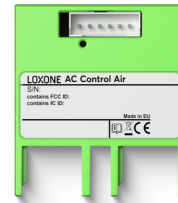

About the product

With the AC Control Air for Sinclair, you can integrate Sinclair air conditioning systems **easily, quickly and seamlessly** into your Loxone installation. The intelligent control of the air conditioning units can significantly increase comfort and at the same time reduce energy consumption by **more than 30%**.

Features:

- Simple, intuitive operation using Loxone controls or the Loxone app
- Heating & cooling according to needs in combination with presence detection, window status, shading and weather forecast
- Cost-effective heating & cooling thanks to integration into the energy management system (e.g. use of PV surplus)
- Optimal coordination of the air conditioning unit with other heating & Cooling sources for maximum energy efficiency
- Simplified integration of the grid-friendly control
- Invisible plug & play installation within the air conditioning system
- Analyze and optimize with individual status messages, statistics and notifications

Electrical Specifications

Power Supply	via AC unit (10 ... 30 VDC)
Power consumption	typ. 0.3 W, max. 0.6 W
Loxone Air	868MHz (SRD Band Europe), 4 channels, max. 15.1mW e.r.p. 915MHz (ISM Band Region 2), 10 channels, max. 13.2mW internal antenna

Ambient Conditions

Temperature	-20 ... 65°C / -4 ... 149°F
Humidity	max. 95% r.H. (non condensing)

Connecting Cable

Wire cross-section	0.14 mm ² / AWG 26
Temperature resistance	80 °C / 176 °F
Length	300 mm / 11.81"
Part. No.	000581

Connection Diagram

Connection Diagram

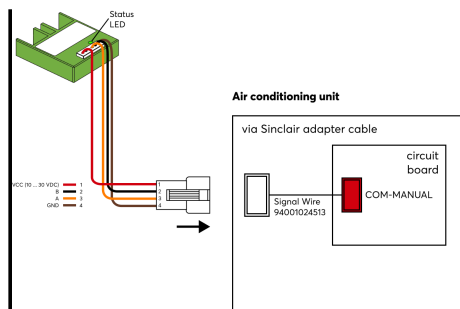

Product Characteristics

Colours	Green: RAL 6018
Finish	Matte

Weight & Dimensions

Net weight	54 g
Total weight	74 g
Product dimensions	38.3 x 34.3 x 10.5 mm / 1.50 x 1.35 x 0.41" (L x W x H)

Product dimensions drawing

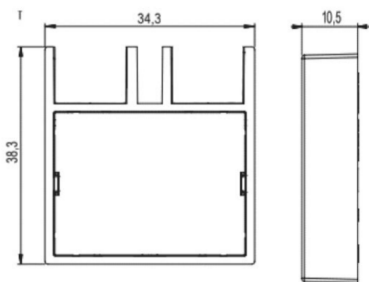

Pack size	79 x 79 x 41 mm / 3.11 x 3.11 x 1.61" (L x W x H)
-----------	---

Certifications & Standards

Safety class	IP20
Certifications	 

LOXONE

Installation must be carried out by a qualified electrician in accordance with the relevant regulations.

Published by

Loxone Electronics GmbH
Smart Home 1
4154 Kollerschlag
Austria
Tel: +43 7287 7070-0
loxone.com

Loxone UK Ltd.
The Forum
Station Road
Theale, RG7 4RA
United Kingdom

Datenblatt

AC Control Air for Sinclair

Part No: 100587

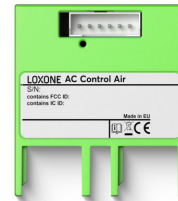

Über das Produkt

Mit dem AC Control Air für Sinclair binden Sie Sinclair Klimaanlage **einfach, schnell und nahtlos** in Ihre Loxone Installation ein. Durch die intelligente Ansteuerung der Klimageräte lässt sich der **Komfort deutlich erhöhen** und der **Energieverbrauch gleichzeitig um mehr als 30% senken**.

Features:

- Einfache, intuitive Bedienung mithilfe Loxone Bedienelementen oder mit der Loxone App
- Bedarfsgerechtes Heizen & Kühlen in Kombination mit Präsenzerkennung, Fensterstatus, Beschattung und Wettervorhersage
- Kostengünstiges Heizen & Kühlen dank Einbindung in das Energiemanagementsystem (z.B.: PV-Überschuss nutzen)
- Optimale Abstimmung des Klimageräts auf andere Heiz- & Kühlquellen für maximale Energieeffizienz
- Erleichterte Integration der netzdienlichen Steuerung
- Unsichtbare Plug & Play-Montage innerhalb der Klimaanlage
- Analysieren und optimieren mit individuellen Statusmeldungen, Statistiken und Benachrichtigungen

Elektrische Spezifikationen

Spannungsversorgung	von Klimaanlage (10 ... 30 VDC)
Leistungsaufnahme	typ. 0,3 W, max. 0,6 W
Loxone Air	868MHz (SRD Band Europa), 4 Kanäle, max. 15.1mW e.r.p. 915MHz (ISM Band Region 2), 10 Kanäle, max. 13.2mW interne Antenne

Umgebungsbedingungen

Temperatur	-20 ... 65°C / -4 ... 149°F
Luftfeuchtigkeit	max. 95% r.H. (nicht kondensierend)

Verbindungskabel

Leiterquerschnitt	0.14 mm ² / AWG 26
Temperaturbeständigkeit	80 °C / 176 °F
Länge	300 mm / 11,81"
Art. Nr.	000581

Anschlussplan

Anschlussplan

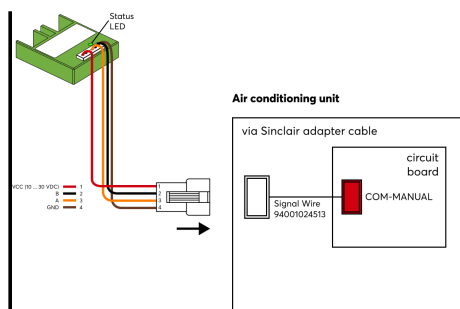

Produkteigenschaften

Farbe	Grün: RAL 6018
Glanzgrad	Matt

Gewicht & Abmessungen

Nettogewicht	54 g
Bruttogewicht	74 g
Produktmaße	38,3 x 34,3 x 10,5 mm / 1,50 x 1,35 x 0,41" (L x B x H)

Produktmaßzeichnung

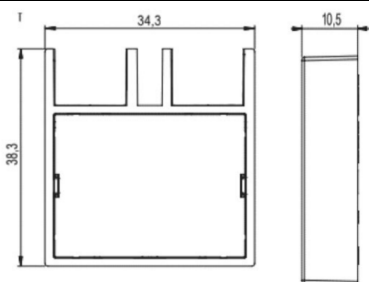

Packmaß	79 x 79 x 41 mm / 3,11 x 3,11 x 1,61" (L x B x H)
---------	---

Zertifizierungen & Standards

Schutzklasse	IP20
Zertifizierungen	 

Die Installation muss von einer qualifizierten Elektrofachkraft gemäß den einschlägigen Vorschriften durchgeführt werden.

Veröffentlicht von

Loxone Electronics GmbH
Smart Home 1
4154 Kollerschlag
Austria
Tel: +43 7287 7070-0
loxone.com

Loxone UK Ltd.
The Forum
Station Road
Theale, RG7 4RA
United Kingdom