

Datasheet

Touch & Grill Air

Part No: 100806



About the product

The Loxone Touch & Grill Air is a **grill thermometer** with **two temperature sensors**, **seven touch points** for operating the most important functions in a room, as well as a **timer** and **temperature alarm**. It combines **user-friendliness** with an architecturally appealing, **clear design**. Whether for measuring temperature while cooking or as a stylish, mobile control element, the Touch & Grill Air can be used flexibly wherever you need it thanks to its **long battery life**.

Features:

- Seven touch points with optional click feedback
- Precise temperature sensors (-15 ... 300°C; cable length: 1.5m)
- User interface made of high-quality real glass
- High-quality feel and appearance
- Maximum user-friendliness

Electrical Specifications

Supply voltage	5 VDC via Micro USB Power supply, integrated Li-Ion Battery
Power consumption	typ. 0.150 W, max. 4 W
Power loss	max. 4 W
Battery lifetime	Stand-by mode - without connected sensors: max. 1 450 h (max. 2 months) Continuous operation - with connected sensors: max. 170 h (max. 7 days) Battery life with active display: max. 7 h

Functional Specifications

Touch points (7)	capacitive touch detection
Click feedback	Yes
Display	time, alarm time, temperature
Timer function	adjustable on the device; built-in alarm signal or playback via Audioserver
Temperature alarm	built-in alarm signal or via Audioserver when target temperature is reached
Temperature sensors (2)	Temperature range: -15 ... 300 °C / 5 ... 572 °F, Cable length: 1 500 mm

Interfaces

Loxone Air	868 MHz (SRD Band Europe), 4 channels, max. 15.1 mW e.r.p. 915 MHz (ISM Band Region 2), 10 channels, max. 13.2 mW internal antenna
------------	--

Ambient Conditions

Temperature	0 ... 40 °C / 32 ... 104 °F
Humidity	max. 95 % r. h. (non-condensing)
Ingress protection	IP20

Connection Diagram

Connection Diagram

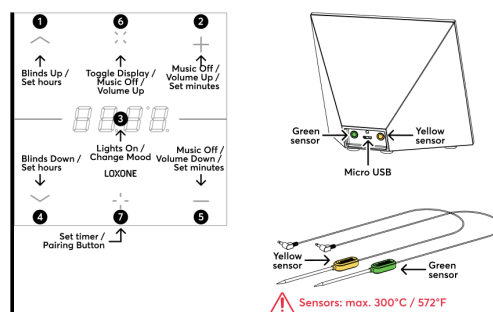

Product Characteristics

Colours	Anthracite: RAL 7016
Finish	Matte

Weight & Dimensions

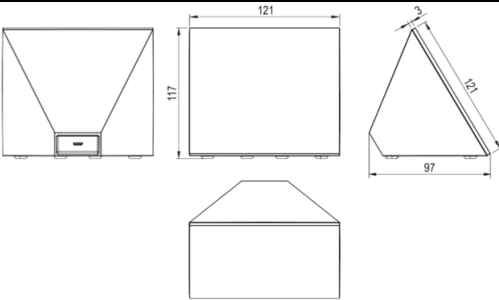
Net weight	418 g
Total weight	790 g
Product dimensions	121 x 121 x 97 mm / 4.76 x 4.76 x 3.82" (L x W x H)
Product dimensions drawing	
Pack size	190 x 215 x 91 mm / 7.48 x 8.46 x 3.58" (L x W x H)

Certifications & Standards



Installation must be carried out by a qualified electrician in accordance with the relevant regulations.

Published by

Loxone Electronics GmbH
Smart Home 1
4154 Kollerschlag
Austria
Tel: +43 7287 7070-0
loxone.com

Loxone UK Ltd.
The Forum
Station Road
Theale, RG7 4RA
United Kingdom

Datenblatt

Touch & Grill Air

Part No: 100806



Über das Produkt

Der Loxone Touch & Grill Air ist ein **Grillthermometer** mit **zwei Temperaturfühlern**, **sieben Tastpunkten** zur Bedienung der wichtigsten Funktionen eines Raumes, sowie **Timer** und **Temperaturalarm**. Er vereint **Benutzerfreundlichkeit** mit einem architekturfreundlichen, **klaren Design**. Ob Temperaturmessung beim Kochen oder als schickes, mobiles Bedienelement – der Touch & Grill Air lässt sich dank **langer Akkulaufzeit** flexibel dort einsetzen, wo Sie ihn benötigen.

Features:

- Sieben Tastpunkte mit optionalem Klick-Feedback
- Präzise Temperaturfühler (-15 ... 300°C; Kabellänge: 1,5m)
- Bedienoberfläche aus hochwertigem Echtglas
- Hochwertige Haptik und Optik
- Maximale Benutzerfreundlichkeit

Elektrische Spezifikationen

Versorgungsspannung	5VDC mit Micro USB Netzteil, integrierter Li-Ion Akku
Leistungsaufnahme	typ. 0,150 W, max. 4 W
Verlustleistung	max. 4 W
Batterie Lebensdauer	Stand-by-Modus - ohne angeschlossene Sensoren: max. 1.450 h (max. 2 Monate) Dauerbetrieb - mit angeschlossenen Sensoren: max. 170 h (max. 7 Tage) Akkulaufzeit bei aktivem Display: max. 7 h

Funktionale Spezifikationen

Tastpunkte (7)	kapazitive Berührungserkennung
Klick Feedback	Ja
Anzeige	Uhrzeit, Alarmzeit, Temperatur
Timer Funktion	am Gerät einstellbar; integriertes Alarmsignal oder Wiedergabe über den Audioserver
Temperatur Alarm	Integriertes Alarmsignal oder über den Audioserver, wenn die Solltemperatur erreicht ist
Temperatursensoren (2)	Temperaturbereich: -15 ... 300 °C / 5 ... 572 °F Kabellänge: 1.500 mm

Schnittstellen

Loxone Air	868 MHz (SRD Band Europa), 4 Kanäle, max. 15,1 mW e.r.p. 915 MHz (ISM Band Region 2), 10 Kanäle, max. 13,2 mW interne Antenne
------------	---

Umgebungsbedingungen

Temperatur	0 ... 40 °C / 32 ... 104 °F
Luftfeuchtigkeit	max. 95 % r. F. (nicht kondensierend)
Schutzart	IP20

Anschlussplan

Anschlussplan

The diagram illustrates the control panel layout with seven numbered touch points:

- 1**: Blinds Up / Set hours
- 2**: Music Off / Volume Up / Set minutes
- 3**: Lights On / Change Mood
- 4**: Blinds Down / Set hours
- 5**: Toggle Display / Music Off / Volume Up
- 6**: Music Off / Volume Down / Set minutes
- 7**: Set timer / Pairing Button

The sensor cable diagram shows a green sensor and a yellow sensor, with a warning: **Sensors: max. 300°C / 572°F**.

Produkteigenschaften

Farbe	Anthrazit: RAL 7016
Glanzgrad	Matt

Gewicht & Abmessungen

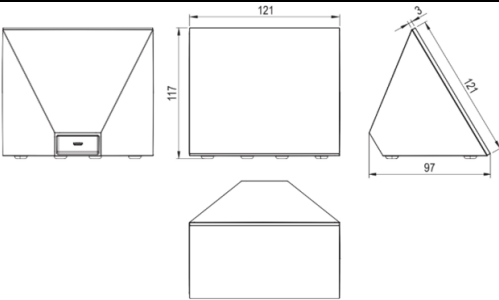
Nettogewicht	418 g
Bruttogewicht	790 g
Produktmaße	121 x 121 x 97 mm / 4,76 x 4,76 x 3,82" (L x W x H)
Produktmaßzeichnung	
Packmaß	190 x 215 x 91 mm / 7.48 x 8.46 x 3.58" (L x W x H)

Zertifizierungen & Standards



Die Installation muss von einer qualifizierten Elektrofachkraft gemäß den einschlägigen Vorschriften durchgeführt werden.

Veröffentlicht von

Loxone Electronics GmbH
Smart Home 1
4154 Kollerschlag
Austria
Tel: +43 7287 7070-0
loxone.com

Loxone UK Ltd.
The Forum
Station Road
Theale, RG7 4RA
United Kingdom